

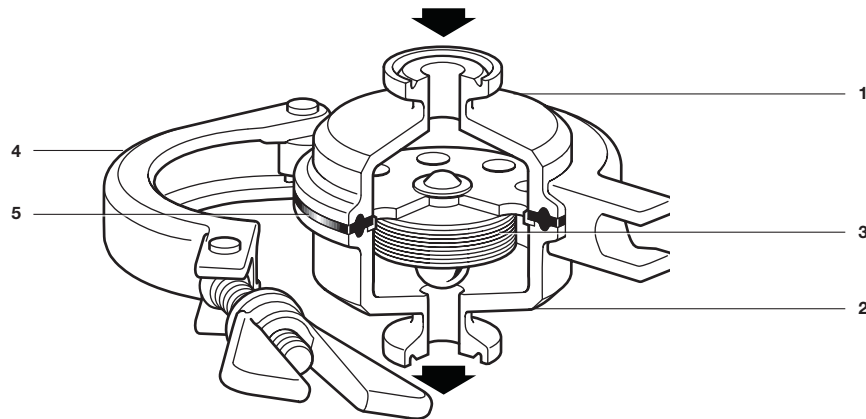

## BT6-B Sanitary Balanced Pressure Thermostatic Steam Trap



### Description

The Spirax Sarco BT6-B sanitary balanced pressure thermostatic steam trap is designed to remove condensate from clean and pure steam applications with minimal condensate retention. Applications include sterile steam barriers, block and bleed installations, mains drainage and CIP/SIP of vessels and reactors and process lines. Manufactured in 316L, the crevice free body design of the BT6-B incorporates a 15° angled seat to ensure full drainability. The standard element is extremely sensitive to changes in condensate temperature and is designed to open with a minimum of sub-cooling, less than 3.6°F (2°C) from steam saturation temperature at pressures below 36 psig (2.5 barg) for typical operating conditions. Exact operating performance may be affected by operating pressure, installation and ambient conditions. Each trap is individually packaged within a 'clean' environment with protective end caps and sealed in a protective plastic bag.

### Available types

<b>BT6-BL</b>	Low capacity
<b>BT6-BH</b>	High capacity

### Body surface finish

(measured to ISO 4287-1997 and ISO 4288-1997):

- Internal surfaces have a finish of mechanical and electropolishing to 0.375 µm (15 µ-in Ra)
- External surfaces have a finish of 1.0 µm (40 µ-in Ra)

### Options:

- For applications requiring closer to steam saturation temperatures, for example, critical SIP applications, please consult Spirax Sarco.
- For dairy applications a PTFE encapsulated Viton seal (item 5) can be supplied.

### Standard

This product fully complies with ASME BPE and the requirements of the European Pressure Equipment Directive 97/23/EC. All seals comply with FDA CFR title 21, part 177, section 1550 and USP24 class VI.

### Certification

This product is available with the following certification at extra cost:

- EN 10204 3.1 material certificates.
- Typical internal surface finish certificates.
- Typical certification of seals FDA/USP compliance.

**Note:** All certification / inspection requirements must be stated at the time of order placement.

### Sizes and pipe connections

½", ¾", 1" and 1½" sanitary clamp ends to ASME BPE.  
For other connections please consult Spirax Sarco.

### Materials

No.	Part	Material
1	Body (inlet)	Stainless steel ASTM A276 316L
2	Body (outlet)	Stainless steel ASTM A276 316L
3	Capsule element	Stainless steel AISI 316L
4	Body clamp	Stainless steel AISI 316
5	Seal	Viton Optionally, for dairy applications, a PTFE encapsulated Viton seal can be supplied.

### Pressure / temperature limits (ISO 6552)

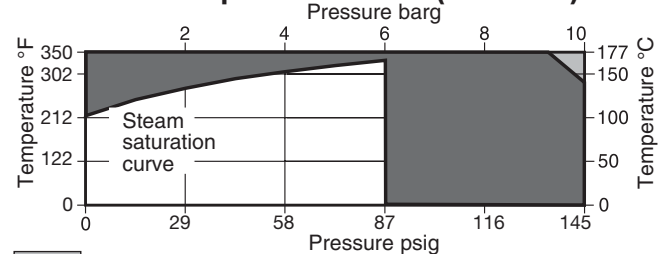

■ The product **must not** be used in this region.

■ The product should not be used in this region as damage to the internals may occur.

**Note:** For hygienic/sanitary clamp ends the maximum pressure / temperature may be restricted by the gasket or sanitary clamp used. Please consult Spirax Sarco.

Body design condition	PN10
PMA Maximum allowable pressure	145psig@284°F (10barg@140°C)
TMA Maximum allowable temperature	350°F@133psig (177°C@9.2barg)
Minimum allowable temperature	-425°F (-254°C)
PMO Maximum operating pressure for saturated steam service	87 psig (6barg)
TMO Maximum operating temperature	329°F@87psig (165°C@6barg)
Minimum operating temperature	32°F (0°C)
Designed for a maximum cold hydraulic test pressure of	218 psig (15 barg)

Local regulation may restrict the use of this product below the conditions quoted. Limiting conditions refer to standard connections only.

In the interests of development and improvement of the product, we reserve the right to change the specification.

TI-P180-30-US 06.10

## Capacities (in accordance with ISO 7842)

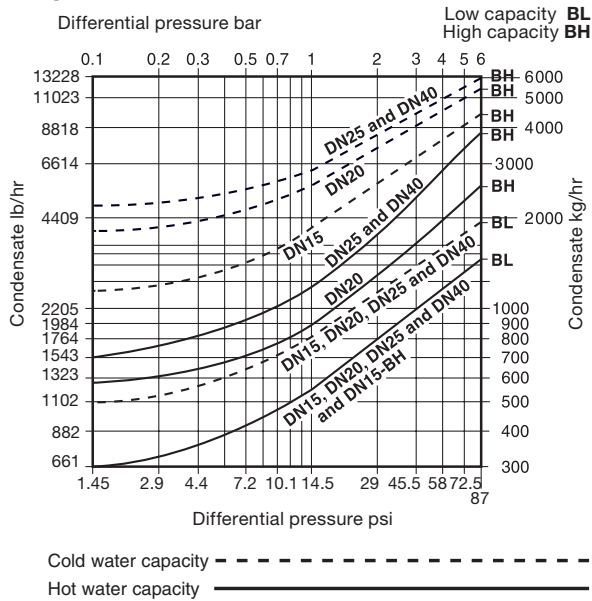

## Safety information, installation and maintenance

For full details see the Installation and Maintenance Instructions (IM-P180-31) supplied with the product.

### Installation note

The BT6-B is designed to be installed in vertical lines with the flow downwards so that the body is self-draining. Check the flow arrow on the body for correct orientation. Fittings and pipe clamps are not supplied.

Installation should include a suitable cooling leg to avoid condensate back-up into process equipment under normal operating conditions.

Do not expose the capsule element to superheat conditions. Handle all components carefully to avoid damage to surfaces.

## Operation

The operation relies on a stainless steel capsule that is filled with a temperature sensing fluid. During cold or start-up conditions the capsule will be fully open allowing large volumes of air, condensate and/or CIP fluid to be drained. As the system approaches steam temperature the fluid in the capsule expands and the valve closes the trap to prevent live steam loss. This closure occurs very close to steam temperature to ensure efficient drainage of the system.

## How to order

**Example:** 1 off Spirax Sarco ½" BT6-BH sanitary balanced pressure thermostatic steam trap with self-draining body. Connections to be sanitary clamp ends to meet the requirements of ASME BPE. Suitable for pressure up to 6 bar g. Internal surface finish to be electropolished to 15 µ-in Ra (0.375 µm). Material certification to EN 10204 3.1 for pressure containing parts.

## Sample Specification

Balanced pressure steam traps with in-line connections shall be designed for specific use in sanitary/hygienic applications. The trap shall be suitable for CIP/SIP systems requiring large cold condensate discharge capacities at low pressures typically encountered at the start of sterilizing cycles. The trap must be available in both high and low capacity versions. High capacity traps must discharge at least 2400 lb/h (1100 kg/h) of cold condensate with 3'3" (1.4 psi) water column differential. Traps must open approximately 3.6°F (2°C) below steam temperature at discharge pressures of 36 psig (2.5 barg) or less for minimal sub-cooling of condensate, and typical condensate back up shall be 6" (150 mm) or less at all times. The trap shall have a sanitary safety body clamp and housing design to prevent accidental disassembly and incorrect reassembly. The trap shall be self-draining with at least a 15° angled seat to ensure full drainability when mounted vertically. Construction shall be of 100% 316L, including bodies, internals and related systems. The maximum allowable internal surface finish for wetted parts shall be 15 µ-inch Ra (0.375 µm), and 40 µ-inch Ra (1 µm) for external surfaces. Traps must comply fully with ASME BPE and the European PED 97/23/EC, and all seals must comply with FDA CFR title 21, part 177, section 1550 and USP24 class VI.

## Dimensions/weights (approximate) in inches and pounds (mm and kg)

Size	A	B	C	D	E	Weight
½"	2.56 (65)	2.52 (64)	2.42 (71.5)	3.03 (77)	2.4 (61)	1.54 (0.70)
¾"	2.56 (65)	2.52 (64)	2.42 (71.5)	3.03 (77)	2.4 (61)	1.56 (0.71)
1"	2.56 (65)	2.52 (64)	2.42 (71.5)	3.03 (77)	2.4 (61)	2.07 (0.94)
1½"	2.56 (65)	2.52 (64)	2.42 (71.5)	3.03 (77)	2.4 (61)	1.89 (0.86)

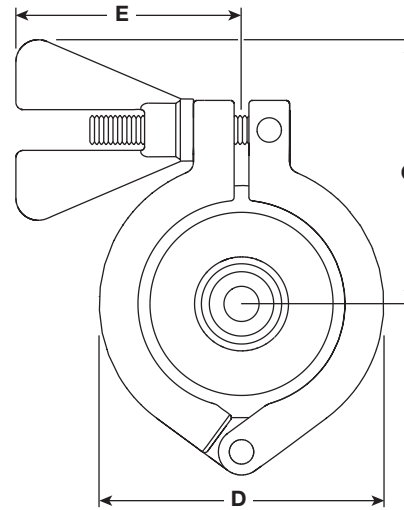
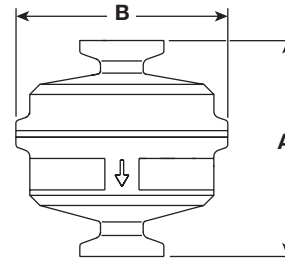

## Spare parts

The available spare parts are detailed below. No other parts are supplied as spares.

### Available spares

Capsule element assembly	3
Seal	5
Body (outlet) including seat	2

### How to order spares

Always order spares by using the description given in the column headed 'Available spares' and state the size and type of trap.

**Example:** 1 - Capsule element assembly for a ½" BT6-BH sanitary balanced pressure thermostatic steam trap.

